

# Technical Data

## Cargo Floor moving floor

### Drive unit CF500 SLC

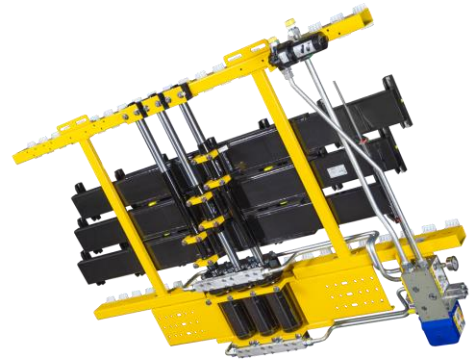

Weight (from) (kg)	<b>450</b>
Available in Cargo Bulkmove execution	<b>Yes</b>
Operating possibilities	<b>E/B/A</b>
Cylinder bore (mm)	<b>100</b>
Piston rod diameter (mm)	<b>45</b>
Working stroke (mm)	<b>200</b>
Cylinder volume (ltr)	<b>2.82</b>
Oil volume per cycle (ltr)	<b>8.45</b>
Working pressure (bar)	<b>170</b>
Max. pressure (bar)	<b>225</b>
Advised oil flow per minute (ltr)	<b>110</b>
Max. oil flow per minute (ltr)	<b>130</b>
Pressure filter (µm)	<b>10</b>
Speed at advised oil flow per minute (m/min)	<b>2.6</b>
Speed at max oil flow per minute (m/min)	<b>3.1</b>
Theoretical unloading time trailer 13.6mtr (min)	<b>6</b>
Max. loading capacity (ton)	<b>40</b>
Advised pump capacity (2-line system):	
Flow per minute (ltr/min)	<b>110</b>
Max. pressure (bar)	<b>250</b>
Pressure piping diameter (mm)	<b>20x2</b>
Return piping diameter (mm)	<b>25x2</b>
Oil tank filling at advised flow (ltr)	<b>110</b>
Oil tank filling at max. flow (ltr)	<b>130</b>
Max. oil temperature	<b>100 °C</b>
Oil type: mineral and biological (hees)	
Temperature range:	
ISO VG32 = -15 < 30 °C	
ISO VG46 = 15 < 40 °C	
ISO VG22 = 25 < -15 °C	